

C-82 HINGES

Technical Specifications & Assembly

DTC C-82 Hinges



Product Features

Aptly named the 'STYLISH' series, the DTC C-82 hinge features a sleek, low-profile design achieved through world-leading innovation. A compact soft-close dampener is cleverly integrated into the hinge knuckle, leaving the cup, arm and plate connection areas free of obstruction. This mini dampener delivers two-stage soft-close performance, ensuring even forcibly shut doors transition smoothly into a gentle, bounce-free close, providing silent, fluid motion every time.

- Elegant & Slim Design
- Miniature Soft Close Dampener
- Complete Family of Hinges / Plates
- CAM Adjustments: Lateral (+2mm / -4mm), Depth (+2.5mm / -2.5mm), Height (+2mm / -2mm)
- Innovative Anyway Clip-on Hinge & Mounting Plate Connection
- TUV tested for 80,000 cycles

What's in the box?

- DTC Hinges
- Doweled, Expansion Dowel, and Screw-on options
- Mounting plates and accessories sold separately

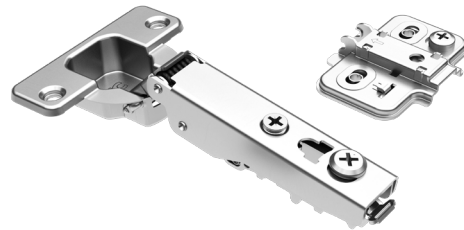

DTC C-82 Series Soft-Close Hinges

Overlay Type	Screw-On Part#	Dowel Part#	Expansion Dowel Part #
110° Full Overlay	105-C82A675F	105-C82A675NF	105-C82A675KF
110° Half Overlay	105-C82B675F	105-C82B675NF	105-C82B675KF
110° Inset	105-C82C675F	105-C82C675NF	105-C82C675KF
45° Cross Corner	105-C82E675F	105-C82E675NF	105-C82E675KF
90° Blind Corner	105-C82J675F	105-C82J675NF	105-C82J675KF
170°	105-C82A605F	105-C82A605NF	105-C82A605KF

DTC C-82 Series Self-Close Hinges			
Overlay Type	Screw-On Part#	Dowel Part#	Expansion Dowel Part #
110° Full Overlay	105-C82A675	105-C82A675N	105-C82A675K
110° Half Overlay	105-C82B675	105-C82B675N	105-C82B675K
110° Inset	105-C82C675	105-C82C675N	105-C82C675K
45° Cross Corner	105-C82E675	105-C82E675N	105-C82E675K
90° Blind Corner	105-C82J675	105-C82J675N	105-C82J675K
170°	105-C82A605	105-C82A605N	105-C82A605K
135° Pie Corner	105-C82H675	105-C82H675N	105-C82H675K
Un-Sprung 110° Full Overlay	--	105-AC82A675NA	--

DTC Clip-On Mounting Plates for C-82 Series Hinges			
Overlay Type	0mm Part#	2mm Part#	4mm Part#
Screw-On	105-82H00AQ	105-82H20AQ	105-82H40AQ
Cam Adjustment, Screw on with pre attached Pan Head Wood Screw	105-82T0PTQ	105-82T2PTQ	105-82T4PTQ
EuroScrew	105-82H02AQ	105-82H22AQ	105-82H42AQ
Cam Adjustment, EuroScrew	105-82T02TQ	105-82T22TQ	105-82T42TQ
Cam Adjustment, 5mm Split Dwl 11.5mm length	105-82T04TQ	105-82T24TQ	105-82T44TQ
Inline, Cam Adjustment, Screw-On	105-82H00YQ	105-82H20YQ	--
Inline, Cam Adjustment, EuroScrew	105-82H02YQ105	105-82H22YQ105	--

DTC Hinge/Plate Accessories	
Description	Part#
86° restrictor clip, for C-80, C-81, C-82 soft-close hinge	105-86S80
Hinge arm cover cap for C-80, C-85, C-82 Hinge	105-S10H-H
Hinge cup cover cap for C-80, C-85, C-82 Hinge	105-G10H
Mounting Jig for DTC Hinges - Insertion Ram	105-HMJI
EuroScrew 6x14mm for Mounting Plates	06-6520
8mm hinge dowel with screw	105-5225

Fixing Method Dimensions

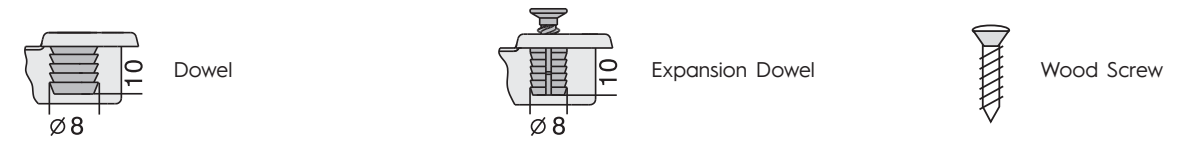

Hinge Cup Patterns and Dimensions for 110° Hinges

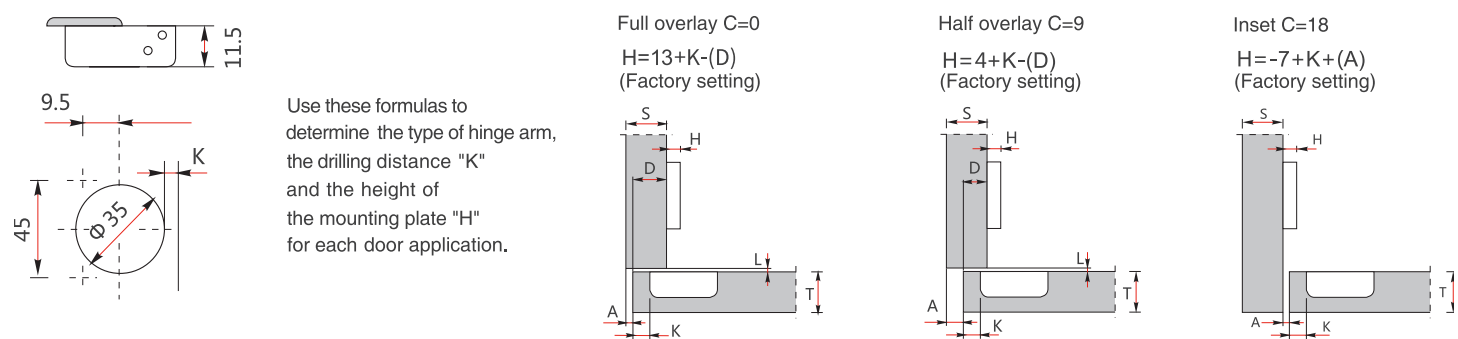

Space Needed to Open the Door for 110° Hinges

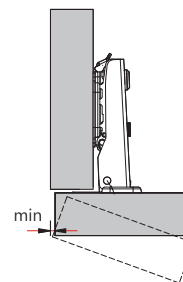

	T=	16	17	18	19	20	21	22	23	24	25	26
K=3	A=	0.6	0.9	1.1	1.4	1.7	2.1	2.5	3.0	3.6	4.4	5.1
K=4	A=	0.6	0.8	1.1	1.3	1.7	2.0	2.4	2.9	3.4	4.0	4.8
K=5	A=	0.6	0.8	1.0	1.3	1.6	1.9	2.3	2.8	3.2	3.8	4.5
K=6	A=	0.6	0.8	1.0	1.3	1.5	1.9	2.2	2.6	3.1	3.6	4.2

-T=Door thickness
-K=Cup hole drilling distance from door edge

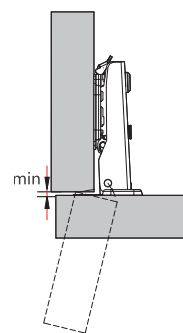

	T=	16	17	18	19	20	21	22	23	24	25	26
K=3	L=	0.0	0.0	0.0	0.0	0.0	0.2	0.5	0.8	1.0	1.3	1.6
K=4	L=	0.0	0.1	0.4	0.7	0.9	1.2	1.5	1.7	2.0	2.3	2.5
K=5	L=	0.8	1.1	1.4	1.6	1.9	2.2	2.4	2.7	3.0	3.2	3.5
K=6	L=	1.8	2.1	2.3	2.6	2.9	3.1	3.4	3.7	3.9	4.2	4.5

- The above values are calculated on the assumption that the doors have square edges.
- They are reduced if the doors have radiused edges.

Projection for 110° Hinges

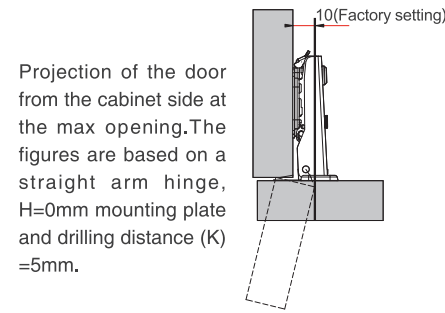

$C = 20 + K + A$

With this formula you can obtain the max thickness of the moulded door that can be opened without touching adjacent carcass sides, doors or walls, while bearing in mind the above L-K-T values.

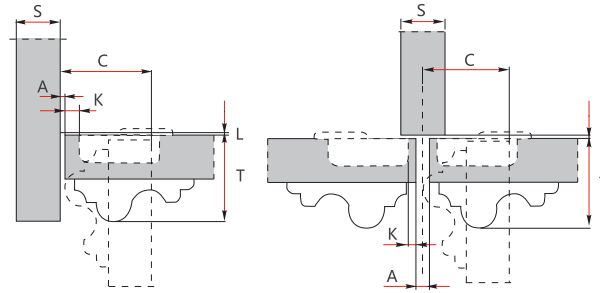

Hinge Cup Patterns and Dimensions for 45° Hinges

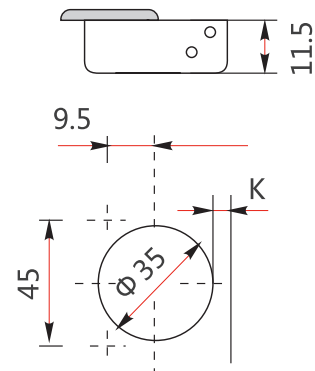

Use these formulas to determine the type of hinge arm, the drilling distance "K" and the height of the mounting plate "H" for each door application.

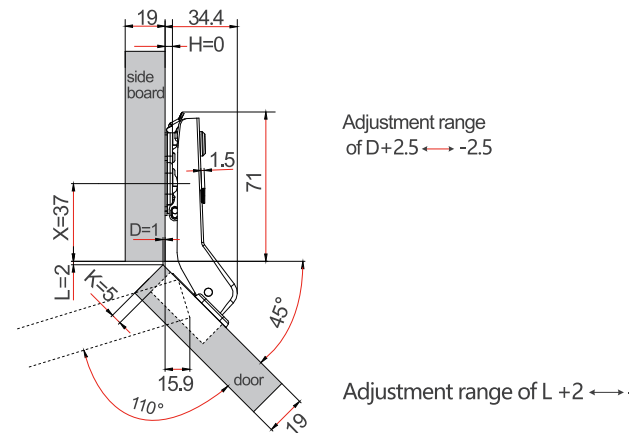

Adjustment range of L +2

Space Needed to Open the Door for 45° Hinges

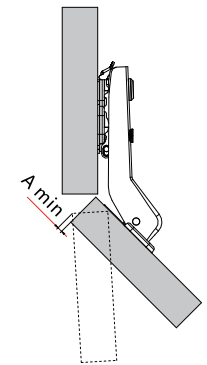

	T=	16	17	18	19	20	21	22	23	24	25	26
K=3	A=	0.6	0.9	1.1	1.4	1.7	2.1	2.5	3.0	3.6	4.4	5.1
K=4	A=	0.6	0.8	1.1	1.3	1.7	2.0	2.4	2.9	3.4	4.0	4.8
K=5	A=	0.6	0.8	1.0	1.3	1.6	1.9	2.3	2.8	3.2	3.8	4.5
K=6	A=	0.6	0.8	1.0	1.3	1.5	1.9	2.2	2.6	3.1	3.6	4.2

-T=Door thickness
-K=Cup hole drilling distance from door edge

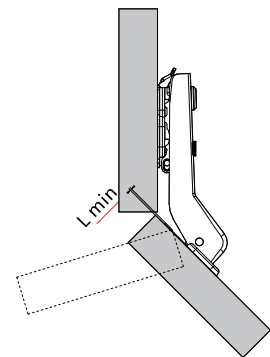

	T=	16	17	18	19	20	21	22	23	24	25	26
K=3	L=	0.0	0.0	0.0	0.0	0.0	0.2	0.5	0.8	1.0	1.3	1.6
K=4	L=	0.0	0.1	0.4	0.7	0.9	1.2	1.5	1.7	2.0	2.3	2.5
K=5	L=	0.8	1.1	1.4	1.6	1.9	2.2	2.4	2.7	3.0	3.2	3.5
K=6	L=	1.8	2.1	2.3	2.6	2.9	3.1	3.4	3.7	3.9	4.2	4.5

- The above values are calculated on the assumption that the doors have square edges.
- They are reduced if the doors have radiused edges.

Hinge Cup Patterns and Dimensions for 90° Hinges

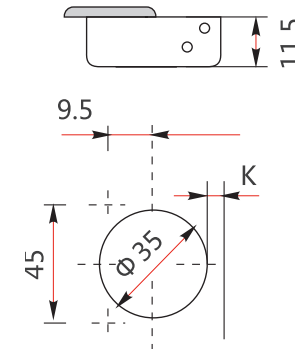

Use these formulas to determine the type of hinge arm, the drilling distance "K" and the height of the mounting plate "H" for each door application.

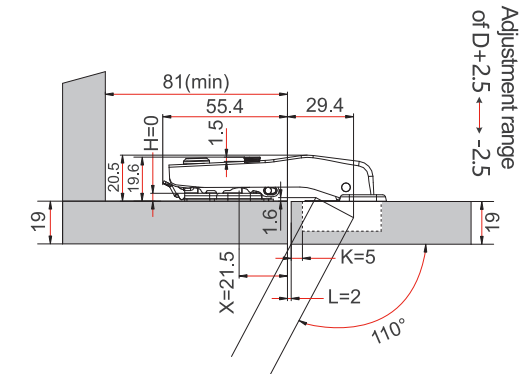

Space Needed to Open the Door for 90° Hinges

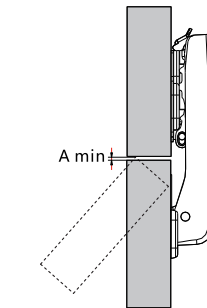

	T=	16	17	18	19	20	21	22	23	24	25	26
K=3	A=	0.6	0.9	1.1	1.4	1.7	2.1	2.5	3.0	3.6	4.4	5.1
K=4	A=	0.6	0.8	1.1	1.3	1.7	2.0	2.4	2.9	3.4	4.0	4.8
K=5	A=	0.6	0.8	1.0	1.3	1.6	1.9	2.3	2.8	3.2	3.8	4.5
K=6	A=	0.6	0.8	1.0	1.3	1.5	1.9	2.2	2.6	3.1	3.6	4.2

-T=Door thickness
-K=Cup hole drilling distance from door edge

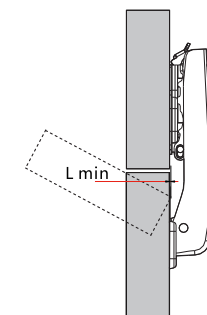

	T=	16	17	18	19	20	21	22	23	24	25	26
K=3	L=	0.0	0.0	0.0	0.0	0.0	0.2	0.5	0.8	1.0	1.3	1.6
K=4	L=	0.0	0.1	0.4	0.7	0.9	1.2	1.5	1.7	2.0	2.3	2.5
K=5	L=	0.8	1.1	1.4	1.6	1.9	2.2	2.4	2.7	3.0	3.2	3.5
K=6	L=	1.8	2.1	2.3	2.6	2.9	3.1	3.4	3.7	3.9	4.2	4.5

- The above values are calculated on the assumption that the doors have square edges.
- They are reduced if the doors have radiused edges.

Hinge Cup Patterns and Dimensions for 170° Hinges

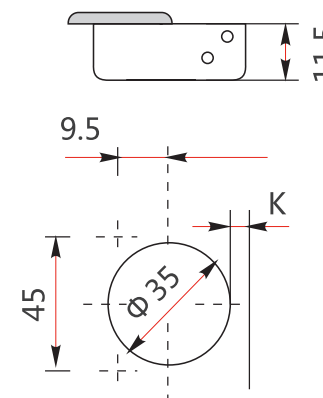

Use these formulas to determine the type of hinge arm, the drilling distance "K" and the height of the mounting plate "H" for each door application.

Full overlay C=0
 $H = 12 + K - (D)$

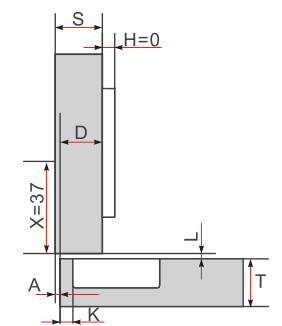

K=5, for full overlay D=17±2mm, H=0 mounting plate only

Space Needed to Open the Door for 170° Hinges

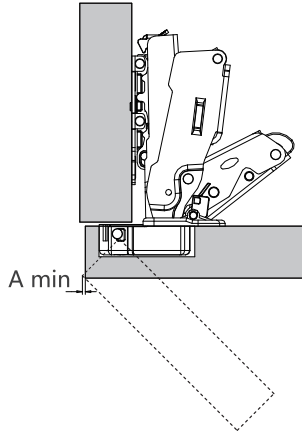

Note: Door protrusions for the 0mm Plate are 5.3mm at a 90° opening, and 0mm at a 170° opening.

	T=	16	17	18	19	20	21
K=3	A=	0.0	0.0	0.0	0.0	0.3	1.1
K=4	A=	0.0	0.0	0.0	0.0	0.1	0.7
K=5	A=	0.0	0.0	0.0	0.0	0.0	0.4
K=6	A=	0.0	0.0	0.0	0.0	0.0	0.3

-T=Door thickness
 -K=Cup hole drilling distance from door edge

Hinge Cup Patterns and Dimensions for 135° Hinges

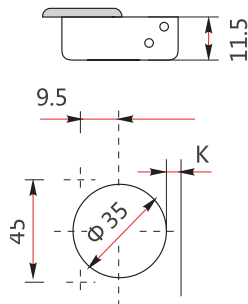

Use these formulas to determine the type of hinge arm, the drilling distance "K" and the height of the mounting plate "H" for each door application.

135°

T=Door thickness D=Required door overlay H=Height of the mounting plate
 X=Distance from bottom plate screw hole to plate edge K=Drilling distance
 L=Gap between door and carcass

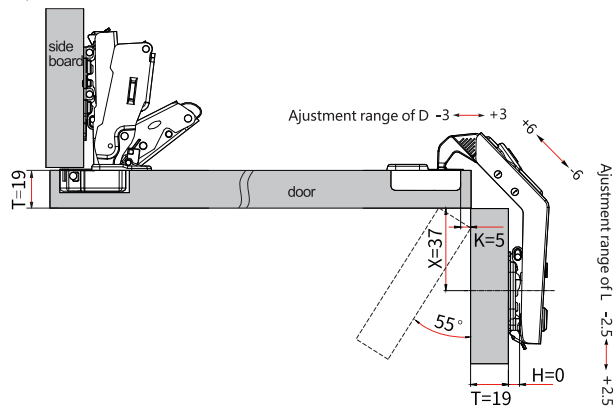

Pcs/ctn
 200

Projection for 135° Hinges

